

# Swimming Pools

***Construction requirements for outdoor private swimming pools (includes inground and above-ground pools).***

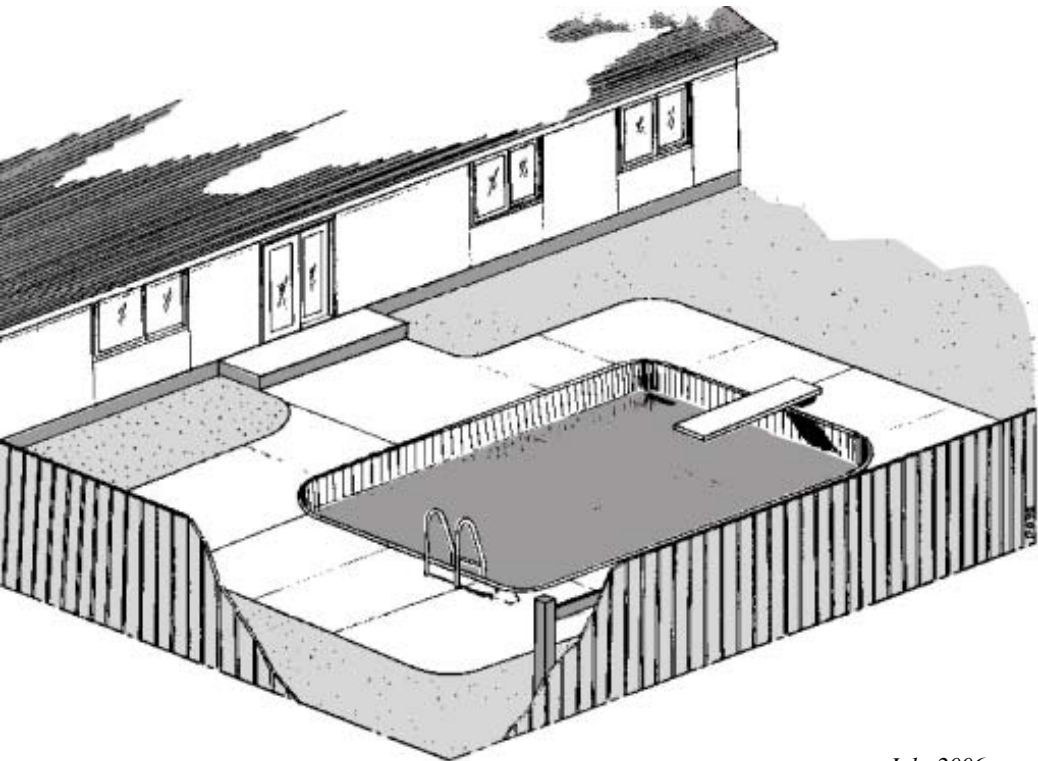

**General Information** \_\_\_\_\_ **4**  
**Zoning** \_\_\_\_\_ **5**  
**Electrical** \_\_\_\_\_ **7**  
**Fencing** \_\_\_\_\_ **9**  
**Hardware** \_\_\_\_\_ **12**  
**Additional Considerations** \_\_\_\_\_ **15**

*Every effort has been made to ensure the accuracy of information contained in this publication. However, in the event of a discrepancy between this publication and the governing City of Winnipeg By-law, the By-law will take precedence.*

## note

***Strive for Safety!*** The primary intent of these regulations is to minimize the danger that pools present for small children. When in doubt, please side with caution.

The Winnipeg Building By-law is primarily an administrative document that adopts the Manitoba Building Code and related standards to provide construction requirements. Throughout this publication the Manitoba Building Code will be referred to as the Building Code.

***When do I contact someone for inspection of my pool?***

You should notify your inspector one day prior to filling your pool; and once again when your fencing and gate(s) are completed.

***Do I require a building permit for a swimming pool?***

YES! A building permit is required to construct a pool or any other structure located outdoors which is capable of containing over 600 mm (2 ft.) of water. This includes inground and above-ground pools, hot tubs, fish ponds, etc.

Permits are also required for associated construction such as decks, change houses, sunrooms, etc.

A waterway permit may be required for construction along city waterways. For more information see the pamphlet called "Construction Regulations Along City Waterways".

***Where can I obtain the necessary permits?***

Permits may be obtained by submitting the required information to the Planning, Property and Development Department, Unit 31 - 30 Fort Street for the building permit.

***What information do I have to bring with me in order to make application for a permit?***

- ***FOR ABOVE-GROUND POOLS*** you require two (2) copies of a Surveyor's Building Location Certificate.

As an alternative, a well drawn site plan may be acceptable. The plan must indicate the size and configuration of existing and proposed structures including the pool and associated structures such as decks, change houses, and sunrooms.

- ***FOR INGROUND POOLS*** you require, in addition to the above, two (2) copies of the structural design drawings of the pool bearing the seal of a Professional Engineer registered in the Province of Manitoba.

### Where on my property can I build the pool?

The Zoning By-law requires that you locate your pool maintaining certain minimum setbacks from your property line. For inground pools see FIGURE 1. For above-ground pools see FIGURE 2.

**NOTE:** If you are planning to construct a deck around your above-ground pool you may require a minimum 7.6 m (25 ft.) rear yard setback. (For more information see the booklet on decks.)

FIGURE 1 - Inground Pools

- a - front yard - same as principle building
- b - side yard - 1.5 m (5 ft.)
- c - reverse corner yard - same as principle building
- d - rear yard - 1.5 m (5 ft.)

(\* a reverse corner lot is a corner lot where it's rear property line abuts the side lot line of an adjoining property.)

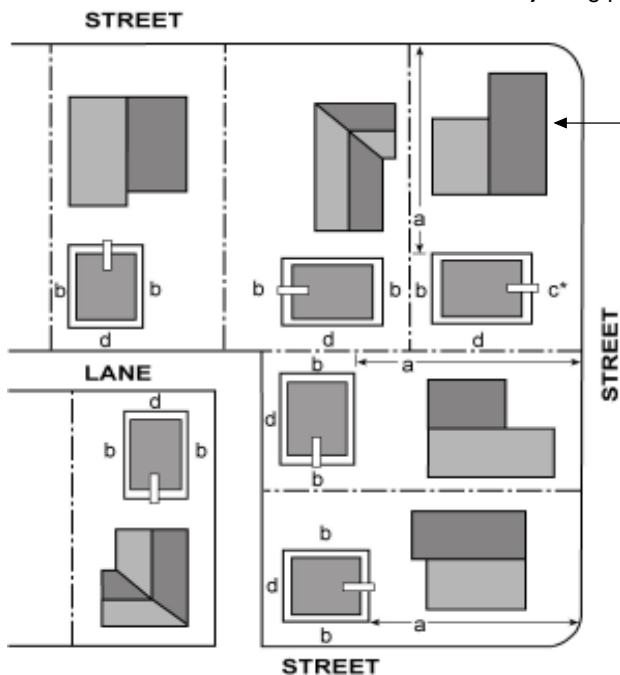

**Where can I locate my pool heater and pump?**

Pool heaters and pumps may be located beside or behind your house as long as they are not closer than 3 m (10 ft.) to an openable window of a habitable room in your neighbour’s house and are at least 600 mm (2 ft.) from a property line.

**NOTE:** Front yard installations are permitted subject to appropriate landscaping.

**NOTE:** Certain *gas heaters and chimneys* may have restrictions on their location based on a minimum distance from nearby combustible materials. Consult with your gas utility company with regard to gas installation codes which may apply.

FIGURE 2 - Above-ground Pools

- a - 600 mm (2 ft.)
- b - 600 mm (2 ft.)
- c - same as dwelling (usually 1.2 m (4 ft.))
- d - same as dwelling (usually 2.7 m (9 ft.))
- e - 18 m (60 ft.) to front property or behind rear wall of dwelling whichever is greater

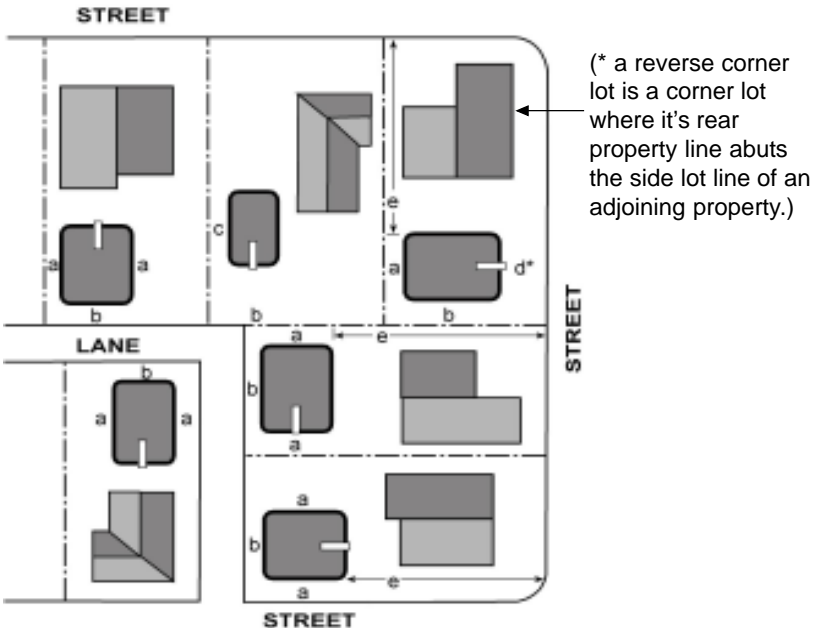

**Are overhead and underground conductors a cause for concern?**

YES! Overhead power supply conductors crossing a pool cannot be less than 7.5 m (25 ft.) above the swimming pool, diving structure, observation stand, tower, or platform. This also applies to the area extending 3 m (10 ft.) horizontally from the pool edge (area above line 2 in FIGURE 3).

However, overhead communication and antenna distribution conductors and neutral supported cables not exceeding 750 volts have a lesser restriction of 4.5 m (15 ft.) above the swimming pool, diving structure, etc. (area above line 1 in FIGURE 3).

No conductors are permitted in the area under line 1 in the diagram below.

For the specific requirements associated with underground wiring close to pools contact The City of Winnipeg Housing Inspections Branch at 986-5300.

**Are there any grounding requirements for swimming pools?**

YES! All metal parts of a swimming pool and other non-electrical equipment associated with the pool including

FIGURE 3 - Overhead Conductors

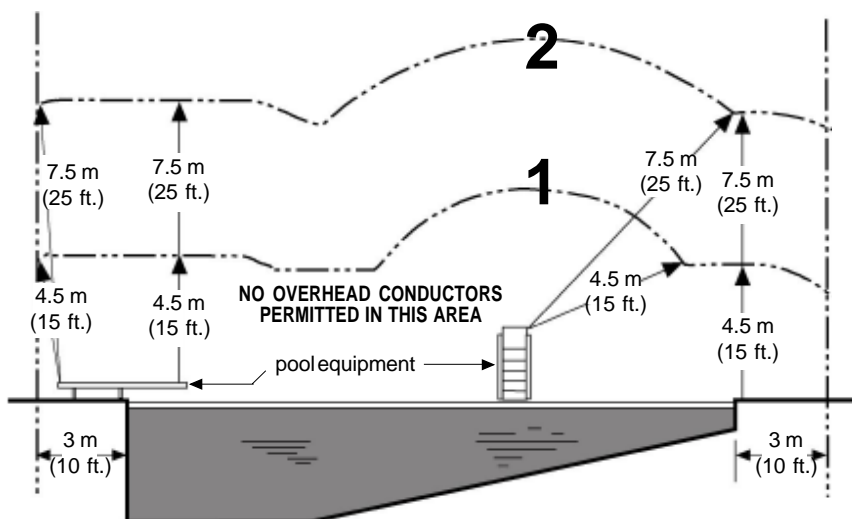

piping, pool reinforcing steel, ladders, diving board supports, etc., must be bonded together if the electrical equipment associated with the pool is located within 3 m (10 ft.) of the pool. Bonding and grounding of metal parts must be provided in accordance with the requirements of the City of Winnipeg Electrical By-law.

The reason for connecting these parts together with a bonding conductor is to ensure that all such metal parts will be at the same electrical potential. This will reduce any possible shock hazard created by stray currents in the ground or piping.

***Are there requirements regarding receptacles, lighting fixtures, and other electrical equipment near a pool?***

YES! Receptacles cannot be located within 1.5 m (5 ft.) of the pool edge. As well, all receptacles located from 1.5 m to 3 m (5 ft. to 10 ft.) from the edge of the pool must be protected by an approved ground fault circuit interrupter.

Lighting fixtures and other electrical equipment located within 3 m (10 ft.) measured both horizontally and vertically from the pool edge, must be protected by an approved ground fault circuit interrupter.

The ground fault circuit interrupter helps protect people from electrical shock. This device can detect when a faulty piece of electrical equipment has a potentially dangerous leakage of electrical current. When such a leakage of current is detected the ground fault circuit interrupter operates by disconnecting the power to the equipment. This device should be tested routinely to ensure proper operation.

***How will I know that my electrical equipment has been properly installed?***

An electrical permit is required for all pool wiring. Consequently, the pool contractor generally hires an electrical contractor who will perform the required work. The electrical contractor will obtain the necessary permit for your pool installation. Upon completion of the wiring, a City of Winnipeg Inspector will check for proper electrical installation.

***If your pool wiring has not been inspected, contact The City of Winnipeg Housing Inspections Branch at 986-5300.***

***What are the requirements for fencing and gates?***

The following requirements for fencing and gates have been extracted from the Building Code on Private Swimming Pools.

All outdoor pools must be completely enclosed with a fence or other suitable barrier constructed in accordance with the following requirements:

- a) it must have a minimum vertical height of 1.5 m (5 ft.) and a maximum vertical height of 2.0 m (6 ft. 6 in.);
- b) there must be no openings, other than a door to a building or a gate as described in requirement (c) below, and it must not be possible for a child to crawl under either the fence or the gate;
- c) any gate must be self-closing, must be at least 1.5 m (5 ft.) in height, and must be equipped with a (self-latching) lockable latch to prevent unauthorized entry;
- d) where chain link is used, the mesh size must not exceed 50 mm (2 in.) and the wire must be at least number 11 gauge;
- e) where other than chain link is used, the outside surface of the fence or gate must be relatively smooth so as not to provide foot or toe holds;
- f) it is not permitted to fill the pool with more than 600 mm (24 in.) of water before the fencing has been completed. Permission may be granted to erect temporary fencing while the permanent fencing is being constructed. Contact the Housing Inspector for your area for more information
- g) if, in the opinion of the authority having jurisdiction, there is any undesirable feature pertaining to the enclosure, suitable steps must be taken to correct the situation.

Furthermore, it is a requirement that the fence be maintained in good repair.

***Are vehicle gates acceptable as part of the fencing?***

The use of vehicle gates as part of the pool enclosure is not recommended. These gates are often too large and too heavy to be automatically closed with most existing hardware. Pairs of gates are also discouraged unless they can be made to close and latch automatically.

The illustrations found on this and the following page are intended as guides in meeting the requirements for construction fences and gates. They are offered as suggestions only. Other alternatives may be used as long as they meet the intent of the Building Code.

**Do all pool gates require this special hardware even if they are seldom used?**

All pool gates require the special hardware.

Vertical Board (picket)

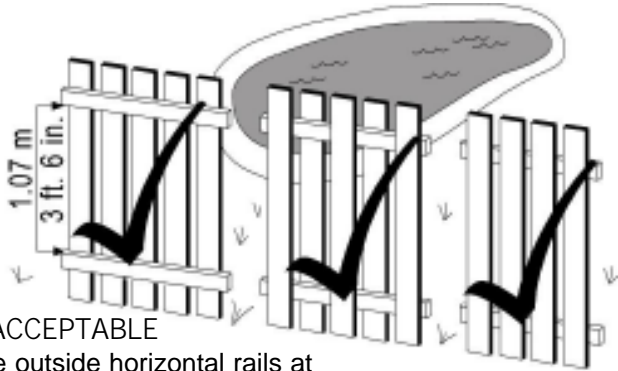

ACCEPTABLE

Place outside horizontal rails at least 1.07 m (3 ft. 6 in.) apart.

NOT ACCEPTABLE

- When building this type of fence avoid closely spaced horizontal rails.
- The fence should not be climbable.



**NOTE:** No style of fence should allow more than 100 mm (4 in.) between the ground and the bottom of the fence.

Wooden Lattice and Horizontal Board

Maximum openings  
50 mm (2 in.)

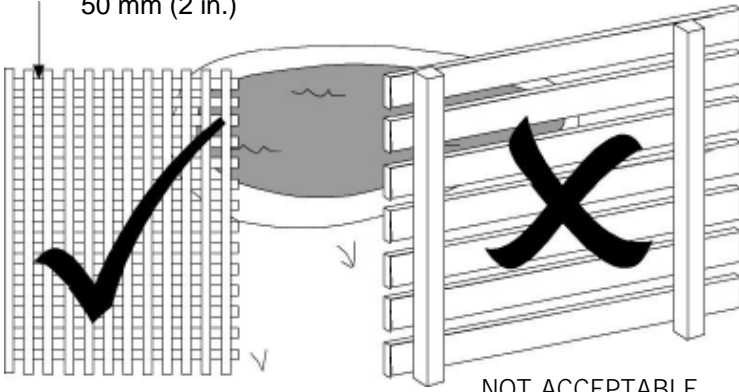

ACCEPTABLE

- Place horizontal straps on the inside of the fence.

NOT ACCEPTABLE

- There can be no space between horizontal boards.

Wrought Iron

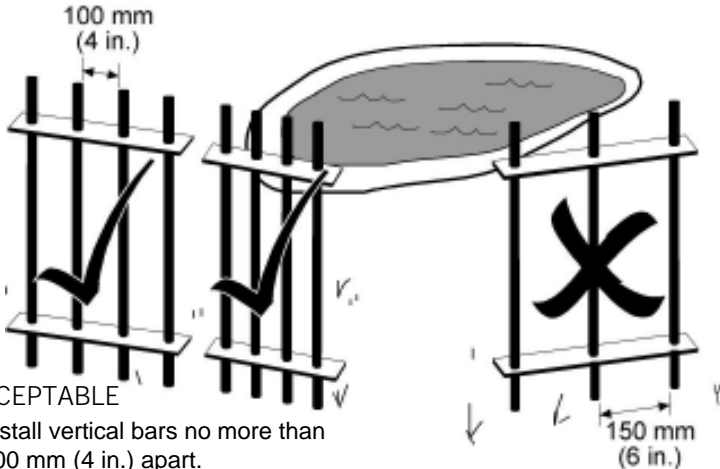

ACCEPTABLE

- Install vertical bars no more than 100 mm (4 in.) apart.
- Avoid the use of any decorative designs or leaf work which could provide foot or toe holds.
- Install the latching in a fashion that it cannot be easily reached through the wrought iron.

NOT ACCEPTABLE

- Bars too far apart.

## SELF-CLOSING DEVICES:

These are defined as devices which will cause any gate to return to a closed position without the aid of a push or pull from a person.

The gate must close automatically to prevent unauthorized entry into the pool area. Self-closing devices must be kept in good repair. Illustrated below are three commonly used types of closers designed to close the gate automatically.

**REMEMBER:**

*These requirements are intended to prevent unauthorized entry of those persons too young to understand the dangers of your pool.*

1. TORSION SPRING  
(pushes gate closed)



2. SPRING LOADED HINGES  
(pushes gate closed)

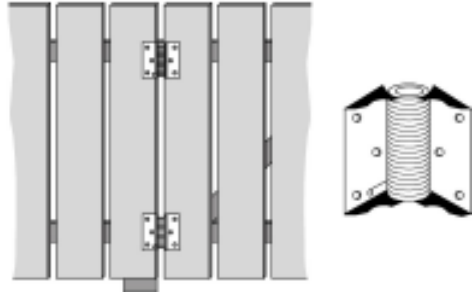

3. HYDRAULIC CLOSER  
(pushes gate closed)

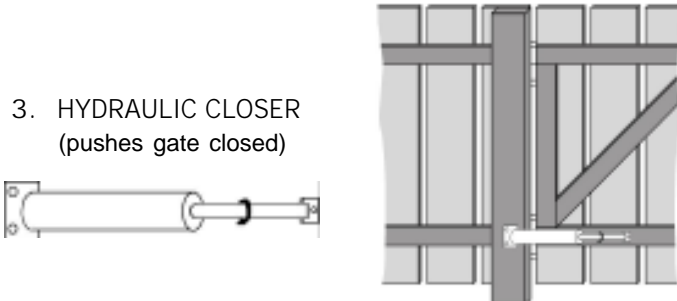

## AUTOMATIC LATCHES:

These are latches which become automatically secured upon contact with the closing gate. Some commonly used types are illustrated below.

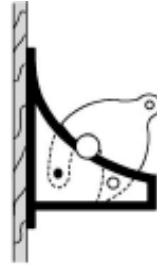
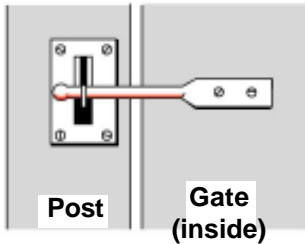

### 1. TONGUE LATCH

Padlocks on gates are recommended when pools are left unattended.

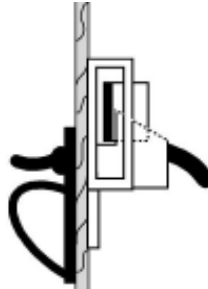
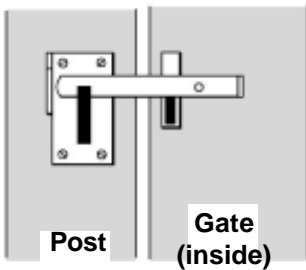

### 2. SLIDING BAR THUMB LATCH

This type of latch is often installed too low. It should be at a height of 1.37 m (4 ft. 6 in.) minimum.

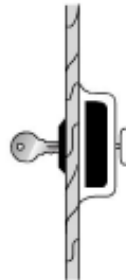
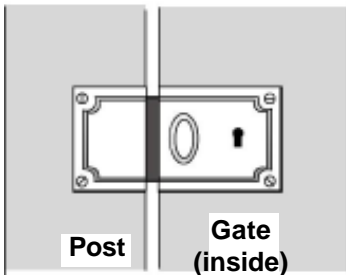

### 3. KEY LATCH

This type of latch is spring loaded.

---

EXAMPLE OF A SELF-CLOSING/AUTOMATICALLY LATCHING GATE:

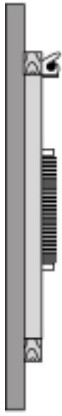

PROFILE

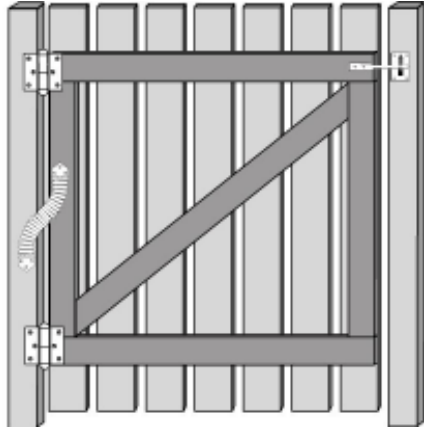

INSIDE VIEW

If a latch cannot be installed on the inside of the gate, install it at a safe height at the top of the gate where it cannot be easily reached by younger persons.

---

UNACCEPTABLE LATCH:



- This latch has to be manually engaged.
- It could impair the gate from self-closing and securing.

***Are there any precautions that should be taken when filling the pool with water?***

YES! It is possible that a garden hose used to fill the pool and left submerged in the water could cause the water supply to the house to become contaminated. A temporary loss of pressure in the City water system could cause the pool water to be drawn by siphon action into the water supply lines in your house. This can be prevented by keeping the end of the hose out of the pool water during filling of the pool or by screwing a small device called a hose bib vacuum breaker onto the outside water tap. The hose bib vacuum breaker will prevent the water from flowing in a reverse direction. It may be purchased from any plumbing supply store. For more information contact The City of Winnipeg Housing Inspections Branch at 986-5300.

***Where can I drain my pool?***

The City of Winnipeg Sewer By-law No. 7070/97 requires that the discharge of water from swimming pools must be to the wastewater sewer system. Swimming pool water and/or swimming pool filter backwash water must not be discharged to any street, lake, lane, or drainage ditch. The wastewater sewer in the house may be utilized by draining, pumping, or back washing filters into the floor drain or catch basin in the basement of your house. For additional information, contact the Public Works Department Customer Service at 986-7623.

***Who is responsible for meeting all of the pool regulations?***

It is the responsibility of the OWNER to ensure that these regulations are met, in particular that the fencing is in good repair and that the pool area is securely maintained at all times.

***Who enforces all of these requirements?***

The Building Inspections Division of the City of Winnipeg Planning, Property and Development Department is assigned the responsibility of monitoring construction for compliance with the various Building Codes and By-laws. This monitoring is carried out by means of the permit approval process and periodic site inspections.

***Is there any way that compliance with a certain aspect of the Building Code can be waived?***

The Building Inspections Division does not have the authority to waive the requirements but it does have the authority to accept equivalencies which meet the intent of the Building Code. If you feel you can satisfy a Building Code requirement by using an equivalent material or construction method, contact your Housing Inspector.

**In-Person Customer Service Hours are:**

Tuesday to Friday 8:30 am to 4:30 pm - All Zoning, Permits and Plan Examination services are available at Unit 31 – 30 Fort Street.

Mondays 8:30 am to 4:30 pm are reserved for telephone inquiries and completed application drop-offs. This enables Zoning and Permits staff to process building and development applications received throughout the week.

Free designated customer parking is available, and located across the street from the 30 Fort Street entrance. Please register your vehicle license number with the receptionist at the Zoning and Permits office.









**Construction Codes (204) 986-5268**

- for building, electrical and plumbing code information

**Zoning By-law (204) 986-5140**

- for property line setback information

**Housing Inspections (204) 986-5300**

- for information or to arrange an inspection call the Housing Inspector for your area between 8:30 & 9:30 a.m. weekdays

**Waterway Inquiries (204) 986-5098**

- for information on construction along a city waterway

**Pool Permit Fees (204) 986-2726**

City of Winnipeg  
Planning, Property and Development Department  
Unit 31 - 30 Fort Street  
Winnipeg, Manitoba  
R3C 4X7

[www.winnipeg.ca/ppd](http://www.winnipeg.ca/ppd)